

TRIANGLE-20

The Triangle-20 resembles the Triangle-10, but is characterised by the double tube which bends forwards.

The user's lock can be secured around the tube at any point. On the Triangle-20 each bicycle can again be attached to its own part of the system, so no two bikes are on the same tube.

The main tube has a diameter of 42.4x3.25 mm. The crossbar onto which the wheel bracket is welded has a diameter of 41.5x2 mm. The wheel bracket is solid and has a 13 mm diameter and a 55 mm gap. The welded base plate is 220x6 mm in diameter and has 3 circular fixing holes Ø12mm.

TRIANGLE CO ORDINATED PRODUCTS

Benches page no. 16 and 17. Litter bin page no. 85.

Bollards page no. 118. Shelters page no. 220 and 221.

Cycle parking page no. 166, 174 and 176.

TRIANGLE-20

Part code	Description
01.555.000	with single-sided 1 low cycle space left, with anchor part
01.555.025	with single-sided 1 low cycle space left, with baseplate Ø 220 mm
01.555.700	additional charge for powder-coated in a RAL colour
01.558.000	with single-sided 1 high cycle space right, with anchor part
01.558.025	with single-sided 1 high cycle space right, with baseplate Ø 220 mm
01.558.700	additional charge for powder-coated in a RAL colour
01.559.000	single-sided high/low, with anchor part
01.559.025	single-sided high/low, with baseplate Ø 220 mm
01.559.700	additional charge for powder-coated in a RAL colour

Triangle-20, Part code 01.555.000

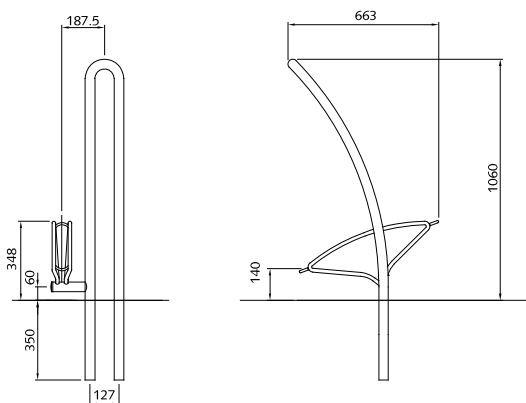

Triangle-20, Part code 01.559.025

